



General Certificate of Secondary Education
2024

Centre Number

--	--	--	--	--

Candidate Number

--	--	--	--	--

Technology and Design

Unit 1:

Technology and
Design Core Content



[GTY11]

GTY11

THURSDAY 30 MAY, AFTERNOON

TIME

1 hour 30 minutes.

INSTRUCTIONS TO CANDIDATES

Write your Centre Number and Candidate Number in the spaces provided at the top of this page.

You must answer the questions in the spaces provided.

Do not write outside the boxed area on each page or on blank pages.

Questions which require drawing or sketching should be completed using an H.B. pencil.

All other questions must be completed using black ink only.

Do not write in pencil or with a gel pen.

Answer **all ten** questions.

INFORMATION FOR CANDIDATES

The total mark for this paper is 100.

Quality of written communication will be assessed in Question **10**.

Figures in brackets printed down the right-hand side of pages indicate the marks awarded to each question or part question.

The Formula sheet is on page 3.

14077



28GTY1101

BLANK PAGE
DO NOT WRITE ON THIS PAGE
(Questions start on page 4)

14077



28GTY1102



Formulae for GCSE Technology and Design

You should use, where appropriate, the formulae given below when answering questions which include calculations.



- 1 Potential Difference = current \times resistance ($V = I \times R$)
- 2 Series Resistors $R_t = R_1 + R_2 + \dots + R_n$
- 3 Gear ratio of a simple gear train = $\frac{\text{number of teeth on driven gear}}{\text{number of teeth on driver gear}}$
- 4 Velocity ratio = $\frac{\text{diameter of driven}}{\text{diameter of driver}}$



1 **Table 1** refers to a number of symbols.

(a) Using the first row as a guide, complete the table.

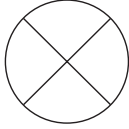
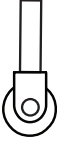
Table 1

Sketch of Symbol	Type of Symbol	Name of Symbol
	Electronic	Bulb
		
		
	Safe Condition Sign	
	Pneumatic	Exhaust

[6]



(b) (i) What do the letters **CAD** stand for?

_____ [1]

(ii) What do the letters **CNC** stand for?

_____ [1]

(iii) State **two** advantages of using **CNC** to manufacture a number of circular discs compared with using a coping saw for the same purpose.

1. _____ [1]

2. _____ [1]

[Turn over



2 (a) **Table 2** lists and defines most of the stages of the design process.

Using the first row as a guide, complete the table.

Table 2

Stage of the design process	Definition
Manufacture	Making the product
Design brief	
	Consider a range of existing solutions and technologies / components that could be used in the design
Testing and evaluation	
Specification	
	Consider the problem

[5]

(b) List **three** methods that could be used to graphically communicate concepts during the idea generation and development stage of the design process in your design portfolio.

1. _____ [1]

2. _____ [1]

3. _____ [1]



(c) Fig. 1 shows a travel cup used to transport hot drinks safely.



Source: CCEA

Fig. 1

Identify **one** ergonomic feature of the travel cup and describe how it improves the ease of use.

Feature _____

Description _____

_____ [2]

[Turn over



3 (a) Mechanical systems make use of different types of motion.

For an **oscillating motion**, give:

- a brief description;
- a simple line drawing to show the motion; and
- a practical example of this type of motion.

Description _____
_____ [1]

Line Drawing _____
_____ [1]

Practical example _____ [1]

(b) Two first class levers labelled **X** and **Y** are shown in **Fig. 2**. The levers are the same length and have the same loads attached.

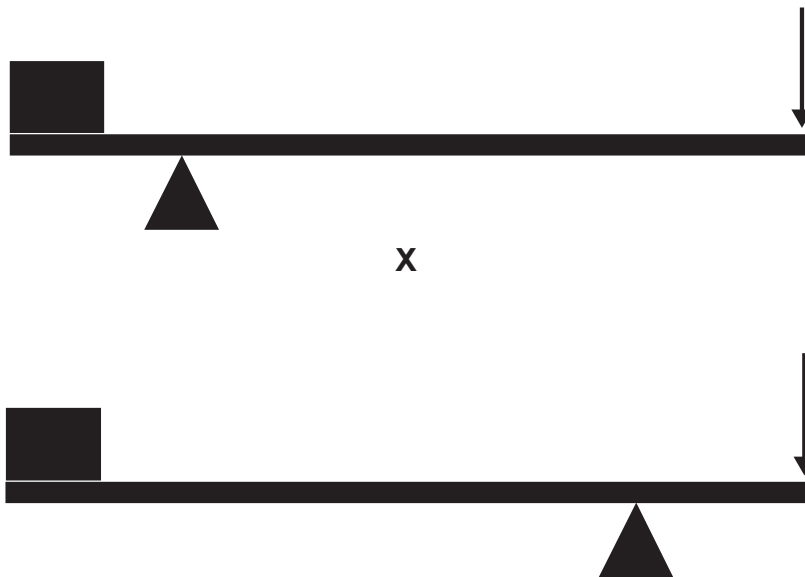

Y
Fig. 2



- (i) Select the lever which requires the greatest effort to lift the load and explain why this lever requires the greatest effort.

Lever _____ [1]

Explanation _____

_____ [2]

- (ii) In the space below, sketch a second class lever. Label the important parts.

[3]

[Turn over

14077



28GTY1109

BLANK PAGE
DO NOT WRITE ON THIS PAGE

14077







28GTY1110



4 **Table 3** shows a number of pneumatic symbols.

Table 3

Symbol	Letter for symbol name
	
	
	
	

(a) Complete **Table 3** by selecting the correct letter for each symbol from **Table 4** below:

Table 4

Name	Letter
Pipeline junction	A
Roller trip	B
Single acting cylinder	C
Shuttle valve	D
Spring return	E
Pressure source	F
Plunger	G

[4]
[Turn over



(b) Fig. 3 shows a pneumatic circuit used in a food processing factory to lift food containers from conveyor belt X to conveyor belt Y.

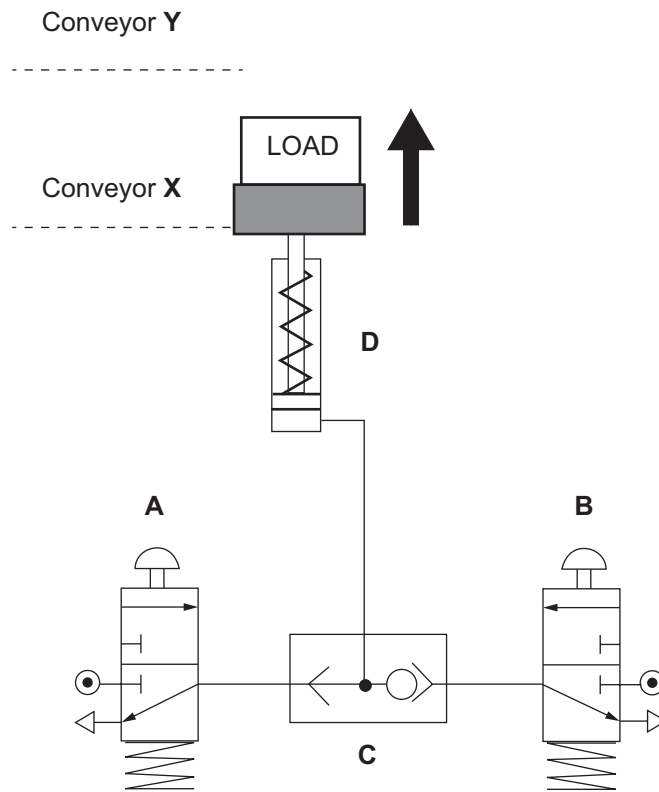

Fig. 3

(i) State **two** reasons for using a pneumatic system in a food processing factory.

1. _____ [1]

2. _____ [1]





(ii) State the logic of the circuit shown in **Fig. 3**.

_____ [1]

(iii) Describe how the circuit in **Fig. 3** operates. Your answer should refer to the function of each component.

_____ [4]



5 (a) Place a tick (✓) in the correct box to respond to each of the following questions.

- A V belt is: used with a gear wheel
used with a pulley wheel
 - A tenon saw is: used to cut straight lines
used to cut curved lines
 - A scriber is: used to mark lines on metal
used to mark lines on wood
 - Acrylic is: a thermosetting plastic
a thermoplastic
 - Graphene is: not as strong as steel
stronger than steel
- [5]

(b) A student has used some mild steel tubing in a project and has decided to apply a dip coating to its surface.

(i) State **two** reasons for dip coating the mild steel tubing.

1. _____
_____ [1]

2. _____
_____ [1]

(ii) Outline how the mild steel tubing should be prepared prior to dip coating.

_____ [2]



6 (a) Three electronic symbols are shown in Fig. 4.

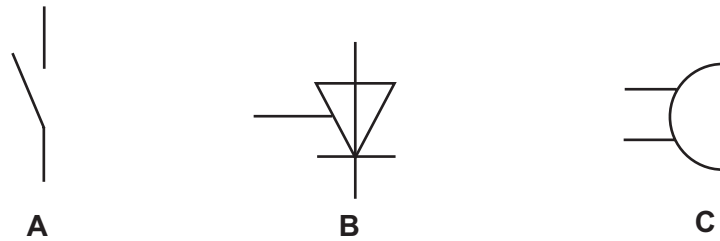

Source: CCEA

Fig. 4

- (i) The symbol labelled **A** in Fig. 4 is an SPST switch. State what the letter **P** in SPST stands for.

_____ [1]

- (ii) Name the components represented by each of the symbols **B** and **C** shown in Fig. 4.

Symbol **B** _____ [1]

Symbol **C** _____ [1]



(b) Fig. 5 shows a partially completed circuit.

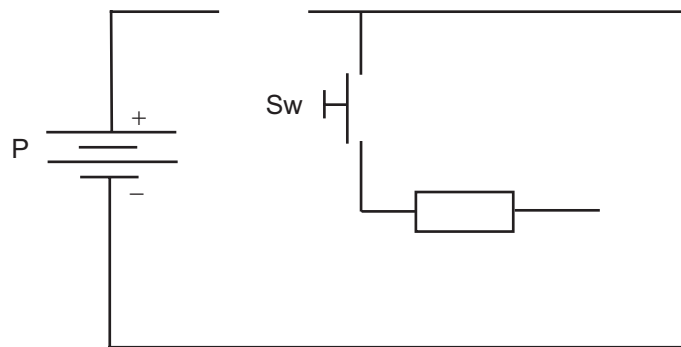

Source: CCEA

Fig. 5

- (i) Symbol **P** in Fig. 5 represents a multi cell battery. State the number of 1.5 volt cells required for a 6 volt multi cell battery.

_____ cells [1]

- (ii) Complete the circuit in Fig. 5 by adding the symbols for components **A**, **B** and **C** from Fig. 4 in the appropriate spaces. When the circuit is completed it should enable component **C** to operate when the switch Sw is pressed for a short time. Assume that component **A** (the SPST switch) is in the closed position. [3]

- (iii) Explain the purpose of component **B** in your completed circuit in Fig. 5.

_____ [2]



(iv) Another partially completed circuit is shown in **Fig. 6**. When the circuit is complete it should consist of the battery, a bulb and two switches. The bulb should light up when **either** of the two switches is operated. Add the appropriate symbols and connections to **Fig. 6** to enable this to happen.

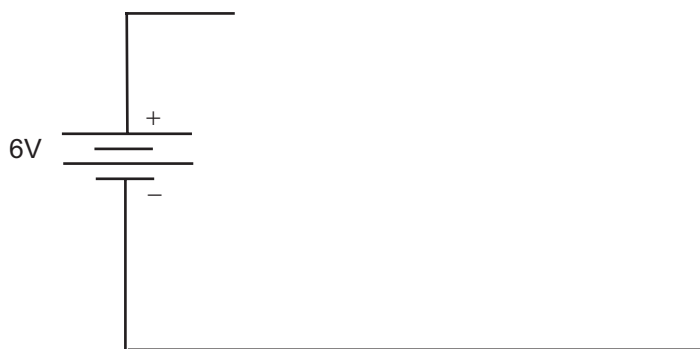

Source: CCEA

Fig. 6

[4]



- 7 **Fig. 7** shows an emergency door system consisting of a door and a sign above it which has two indicator lights. The emergency door has a sensor that detects when the door is pushed open.

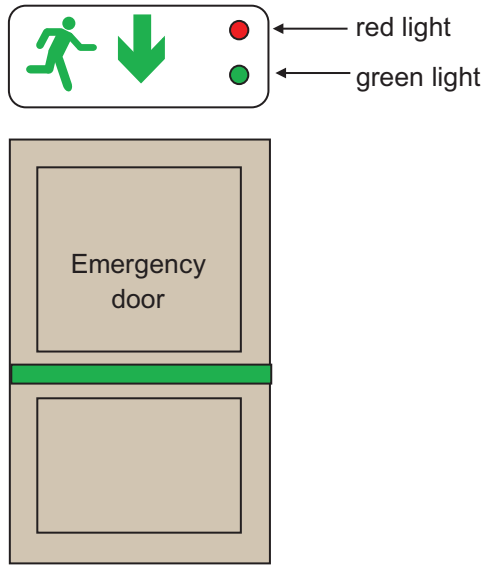

Source: CCEA

Fig. 7

The emergency door system operates as follows:

- When the door is closed, the green light will be on and the red light will be off.
- If the sensor detects that the door has been opened, the green light will switch off immediately and the red light will then repeatedly flash on and off (on for 0.5 seconds and off for 1 second).
- The red light will continue to flash until the door is closed.
- When the door is closed, the flashing red light will switch off and the green light will switch on again.

Complete the flow chart in **Fig. 8** to illustrate the program to run the emergency door system.



START



Fig. 8

[9]

[Turn over

14077



28GTY1119

8 Fig. 9 shows a greenhouse manufactured from aluminium alloy.



Source: © Getty Images

Fig. 9

(a) (i) Aluminium alloy is a non-ferrous metal. State **one** other property of aluminium alloy that makes it a suitable material for the greenhouse frame.

_____ [1]

(ii) Define the term non-ferrous.

_____ [1]

(b) An alternative design uses softwood to produce greenhouse frames. Name a suitable softwood with appropriate weather resistant properties for the construction of the frame.

_____ [1]



(c) Suggest **two** advantages of the metal-framed greenhouse compared to a wooden-framed greenhouse.

1. _____

2. _____

_____ [2]

(d) The manufacturer is going to make use of thermochromic pigments in their new greenhouses.

Explain the action of thermochromic pigments and state why they would be suitable for use in a greenhouse.

_____ [3]



9 Fig. 10 shows a pneumatic component.



Source: CCEA

Fig. 10

(a) (i) Name the pneumatic component shown in Fig. 10.

_____ [1]

(ii) Which one of the following is used to actuate the component shown in Fig. 10?

Roller Push Button Lever Plunger

_____ [1]

(b) Fig. 11 shows a pneumatic circuit used to crush aluminium cans for recycling.

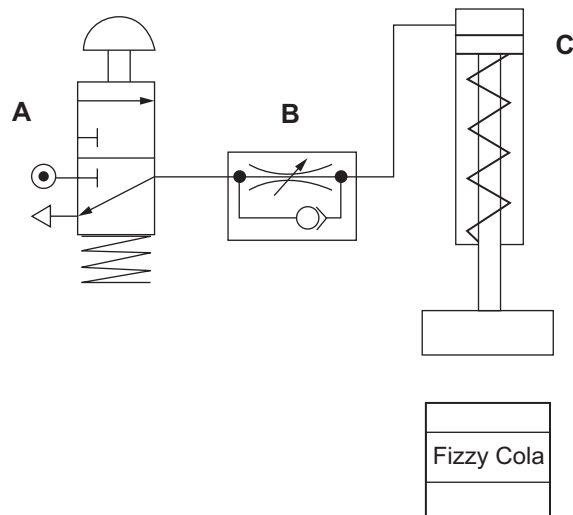

Fig. 11



(i) Explain the operation of the crusher as shown in **Fig. 11**.

[4]

(ii) Name component **B** shown in **Fig. 11**.

[1]

(iii) Name component **C** shown in **Fig. 11**.

[1]

(iv) Currently, the circuit in **Fig. 11** can be actuated with one hand. Explain how the circuit could be modified to require two hands to actuate.

[2]

(v) Give a reason for this modification.

[1]

[Turn over



BLANK PAGE
DO NOT WRITE ON THIS PAGE

14077



28GTY1126





BLANK PAGE
DO NOT WRITE ON THIS PAGE

14077



28GTY1127

DO NOT WRITE ON THIS PAGE

For Examiner's use only	
Question Number	Marks
1	
2	
3	
4	
5	
6	
7	
8	
9	
10	
Total Marks	

Examiner Number

Permission to reproduce all copyright material has been applied for.
In some cases, efforts to contact copyright holders may have been unsuccessful and CCEA will be happy to rectify any omissions of acknowledgement in future if notified.

GTY11/7
289826



28GTY1128